

Implementation of Nth Order Bandpass filter

S.Shirin, CH.R.Phani Kumar

Dept. of ECE, Gitam University, Andhra Pradesh, India

Abstract— The bandwidth of the wireless signals been separated by means of channels and are sent to the base station for Transmission and reception in wireless communications. Each channel is of different frequency and the corresponding transmitter and receiver are able to identify the signals of the respective channel without any noise. To design a basic multiple N order Band Pass filter for the wireless communication systems, The Wavelength Division Multiplexing is the basic technology which is used to process the signals in this present work with help of the filter network, previously the work is carried with respect to photonics and optical fibre communications. And the signalling is purely by means of a optical fibre cable, for a point to point contact communication the present work is not suitable, As the antennas used are for radio frequency and will operate in the same frequency for which the operator/Mobile radio is dedicated. The present work carries the better out come for line of site communication without any noise and interference by means of the N th order multiple filter.

Keywords — Bandpass filter, filter bank, butterworth response, MATLAB

I. INTRODUCTION

One of the major factors influencing the development of signaling systems is the relationship between signalling and the control function of exchanges. Early telecommunication networks used analogue step-by-step exchanges. In such systems, the control and switch functions are co-located, and when a call is made, the signalling and traffic follows the same path within the exchange. This is known as Channel Associated Signaling (CAS). In this case, the signalling and traffic also follows the same path external to the exchange, i.e. on the transmission link

The next stage through, which the exchanges evolved, is shown in Fig1. In such exchange the control mechanism for setting-up and releasing calls is separated from the switch block. The technique allows much more flexibility in controlling calls and it also reduces costs. Again, CAS system are typically associated speech circuit external to the exchange. The speech traffic circuits (denoted by solid lines) are routed by the switch block but the signalling information (denoted by dotted lines) is routed via the control function. Between Exchanges A and B, the signalling and traffic are carried over the same path. This approach was primarily designed to allow optimisation of functions within exchanges, but its effectiveness is constrained by the need to combine signalling and speech traffic external to the exchange

With Common Channel Signalling (CCS) systems, the philosophy is to separate the signalling path from the speech path. The separation occurs both within the exchange and external to the exchange thus following optimisation of the control processes, switch block routes

the signalling (denoted by a dotted line). The approach gains maximum benefits when adopted in parallel with the introduction of digital exchange and digital transmission systems. CCS system being particularly efficient in these circumstances.

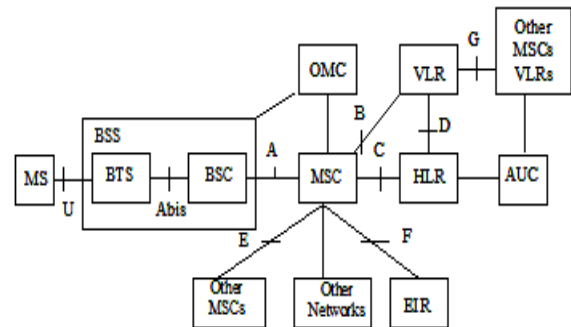

Fig1. Cellular Network Concept

Previously the work is carried with respect to photonics and optical fiber communications. And the signalling is purely by means of a optical fiber cable, for a point to point contact communication the present work is not suitable, As the antennas used are for radio frequency and will operate in the same frequency for which the operator/Mobile radio is dedicated. The present work carries the better out come for line of site communication without any noise and interference by means of the N Th order Bandpass multiple filter.

II. BANDPASS FILTER

The bandpass filter is an electronic device or circuit that allows signals between two specific frequencies to pass, but that discriminates against signals at other frequencies. Some bandpass filters require an external source of power and employ active components such as transistors and integrated circuits; these are known as active bandpass filters.

Other bandpass filters use no external source of power and consist only of passive components such as capacitors and inductors; these are called passive bandpass filters. The cut-offs frequencies, f_1 and f_2 , are the frequencies at which the output signal power falls to half of its level at f_0 , the centre frequency of the filter. The value $f_2 - f_1$, expressed in hertz (Hz), kilohertz (kHz), megahertz (MHz), or gigahertz (GHz), is called the filter bandwidth. The range of frequencies between f_1 and f_2 is called the filter passband of passive components such as capacitors and inductors; these are called passive bandpass filters

A band-pass filter is a device that passes frequencies within a certain range and reattenuates frequencies outside that range.

By connecting or cascading together a single low pass filter circuit with a high pass filter circuit, passive RC circuit is obtained that passes a selected range or band of frequencies that can be either narrow or wide while attenuating all those outside of this range.

Bandpass filters are used primarily in wireless transmitters and receivers. The main function of such a filter in a transmitter is to limit the bandwidth of the output signal to the minimum necessary to convey data at the desired speed and in the desired form. In a receiver, a bandpass filter allows signals within a selected range of frequencies to be heard or decoded, while preventing signals at unwanted frequencies from getting through. A bandpass filter also optimizes the signal-to-noise ratio (sensitivity) of a receiver

In both transmitting and receiving applications, well-designed bandpass filters, having the optimum bandwidth for the mode and speed of communication being used, maximize the number of signals that can be transferred in a system, while minimizing the interference or competition among signals.

The most common filter responses are the Butterworth, Chebyshev, and Bessel types. Among these responses, Butterworth type is used to get a maximally-flat response. Also, it exhibits a nearly flat pass band with no ripple

III. FILTER BANK

In signal processing, a filter bank is an array of band-pass filters that separates the input signal into multiple components, each one carrying a single frequency subband of the original signal. One application of a filter bank is a graphic equalizer, which can attenuate the components differently and recombine them into a modified version of the original signal. The process of decomposition performed by the filter bank is called analysis (meaning analysis of the signal in terms of its components in each sub-band); the output of analysis is referred to as a subband signal with as many subbands as there are filters in the filter bank. The reconstruction process is called synthesis, meaning reconstitution of a complete signal resulting from the filtering process.

In digital signal processing, the term filter bank is also commonly applied to a bank of receivers. The difference is that receivers also down-convert the subbands to a low centre frequency that can be re-sampled at a reduced rate. The same result can sometimes be achieved by undersampling the bandpass subbands.

IV. IMPLEMENTATION

Each channel is allocated its own wavelength or rather range of wavelengths. This channel is a wavelength range within which the signal must stay.

A. Transmitter

In practical terms, the transmitters is always a signal. It must have a bandwidth which fits easily within its allocated band. It must not go outside the band such that the signal stays where it supposed to be.

B. Combining The Signals

In this channels are been combined and cascaded such that lower loss is obtained

C. Transmission

In transmission, the main issue is controlling crosstalk effects, here the particular frequency which is passing through the channel is attenuated to minimize crosstalk.

D. Separating Channels At The Receiver

Here nth order bandpass filter is situated such that identification of the signals of the respective channel without any noise is done.



Fig2. Identification Of Signals

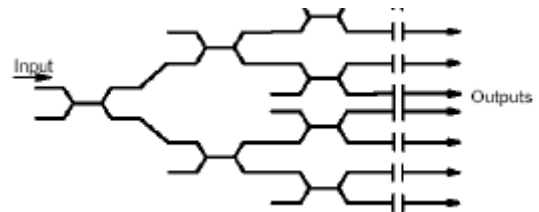

Fig3. Subdivision of The Individual Filtered Output Signals

V. SIMULATED RESULTS

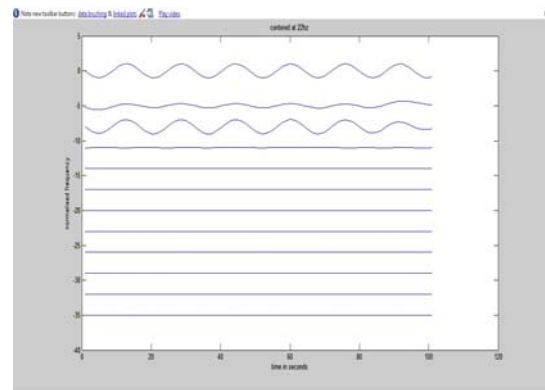

Fig3 Butterworth Filter Bank Output

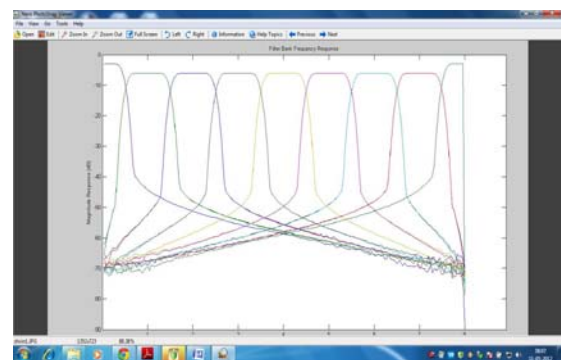

Fig4 Filter Response

VI. CONCLUSION

Band-pass filter and simulation for filter bank is presented in this paper. As the simulated results satisfy the system requirements, these are used in RFID application, signal compression and vocoder. If more-accurate frequency response is required, more multiple filters should be used. It is shown from the results that we can get fast and exact designs using MATLAB of nth order Butterworth filter for practical implementations with very high flexibility. It is easy to scale the results using MATAB and we can easily get the required results. The designs are optimized to synthesize any order without order limits. Matlab program of nth order bandpass filter is very flexible design approach of filters' frequencies and components.

REFERENCES

- [1] P. Löwenborg, O. Gustation, and L. Wanhammar: "Filter Design Using MATLAB", Radioteknik och Kommunikation 99, Karlskrona, June 1999
- [2] P. Löwenborg, H. Johansson, and L. Wanhammar, "A Class of Two-Channel Hybrid Analog/ Digital Filter Banks", IEEE Midwest Symp. Circuits Systems, Las Cruces, New Mexico, Aug., 1999.
- [3] P. Löwenborg, H. Johansson, and L. Wanhammar, "A Design Procedure for 2-Channel Mixed Analog and Digital Filter Banks for A/D Conversion Using Minimax Optimization", IEEE Int. Conf. Elect. Circuits Syst., Cyprus, Sept., 1999.
- [4] S. Winder, "Analog and Digital Filter Design", 2nd ed. Woburn, MA: Newnes 2002.
- [5] P. Löwenborg, H. Johansson, and L. Wanhammar, "A Design Procedure for 2-Channel Mixed Analog and Digital Filter Banks for A/D Conversion Using Minimax Optimization", IEEE Int. Conf. Elect. Circuits Syst., Cyprus, Sept., 1999.